

Please Approve this Drawing
Date
Signature

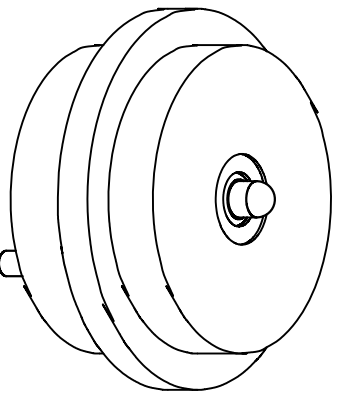
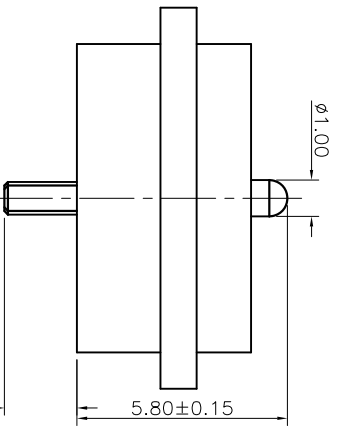
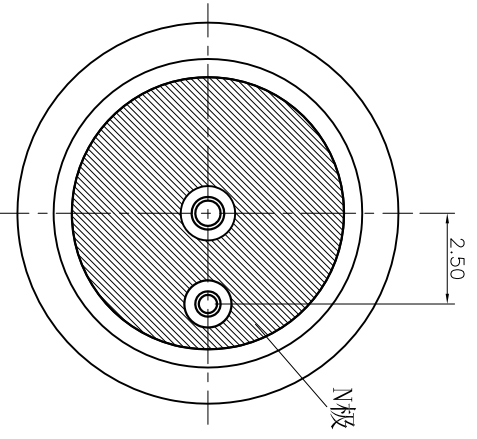
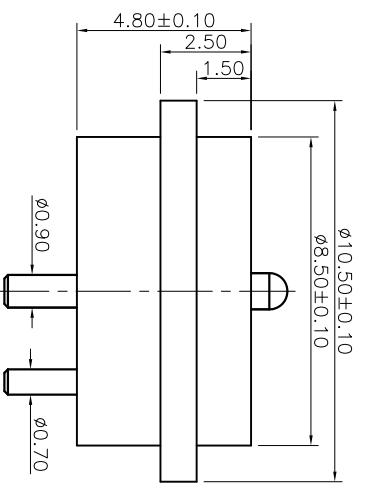
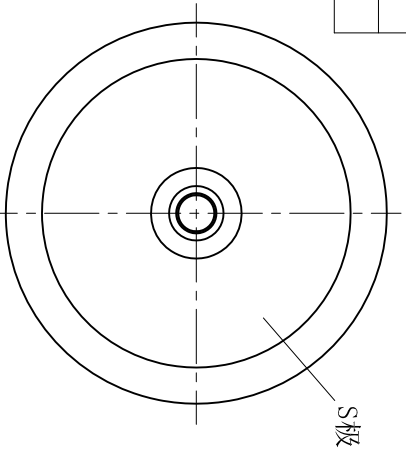

NO.	Part Name	Q'ty	Material	Plated surface
1	Plunger	2	无铅铜	Au 5u" Min. Over 50u" Min. Ni
2	Barrel	2	无铅铜	Au 3u" Min. Over 50u" Min. Ni
3	Spring	2	SUS304	/
4	Housing	1	High temp. Plastic	UL94 V-0 Color Black
5	Magnet	1	MS2	Plating Ni
6	Shell	1	无铅铜	/

NOTES:

- Electrical
Rated Current & Voltage : DC 12 V ; 3.0A Max.
Contact Resistance: 50 mohm maximum
at Working Height(Quiescence)
- Mechanical
Full store: 1.10 mm
Working Store: 1.00 mm
Spring Force: 90±20gf at Working Height
Durability: 10,000 cycles(minimum)
- Environmental
Operating Temperature: -30°C~+85°C
Humidity Range: 10%RH~90%RH
Salt Spray: 48 Hours
Dustproof and waterproof: IP65
- When the current is greater than 1A then need to increase the time delay circuit(3 second)
- To avoid arcing issue, The adaptor start to power supply after connector mated fully.
- To ensure the best usage, please operate it based on the working height.
- Rohs&HF compliant product.

VER.	DESCRIPTION	ECN NO.	DATE

DRAWN	DATE	2022.05.09		DRAWING NO.	NC4601-02PB	mm	Ang:	Dim:
lys	SCALE	10:1	VER. B.0					
CHECKED						0 ±0.5°	0 ±0.15	
APPROVED						0 ±0.25°	0 ±0.10	
PROJECT								
SHEET	1 of 1	UNIT						

东莞市燊瑞电子科技有限公司