

Please Approve this Drawing
Date
Signature

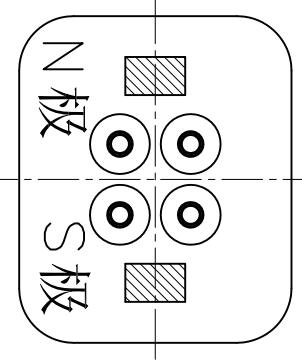
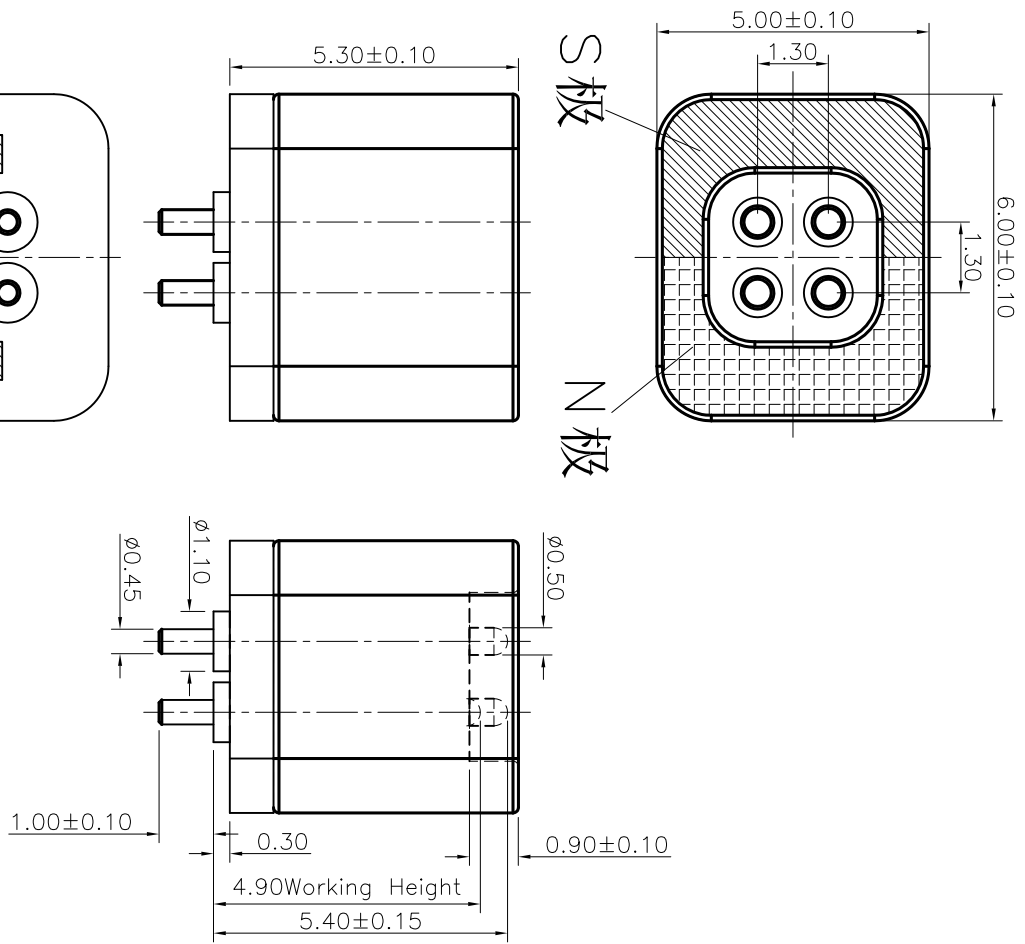

NO.	Part Name	Q'ty	Material	Plated surface
1	Plunger	4	无铅铜	Au 5u" Min. Over 50u" Min. Ni
2	Barrel	4	无铅铜	Au 3u" Min. Over 50u" Min. Ni
3	Spring	4	SUS304	/
3	Ball	4	SUS304	Au 1u" Min. Over 50u" Min. Ni
4	Housing	1	High Temp Plastic: UL94 V-0 Color Black	
5	Magnet	1	N42Feb	Plating Ni

NOTES:

- Electrical
 .Rated Current & Voltage : DC 12 V ; 2.0A Max.
 .Contact Resistance: 50 mohm maximum
 at Working Height(Quiescence)
- Mechanical
 .Full store: 0.70 mm
 .Working Store: 0.50 mm
 .Spring Force: 30gf±10gf at Working Height
 .Durability:10,000 cycles(minimum)
 .Environmental
 .Operating Temperature: -30°C~+60°C
 .Humidity Range: 10%RH~90%RH
 .Salt Spray: 48 Hours
- When the current is greater than 1A then need to increase the time delay circuit(3 second)
- To avoid arcing issue, The adaptor start to power supply after connector mated fully.
- To ensure the best usage,please operate it based on the working height.
- .RoHS&HF compliant product.

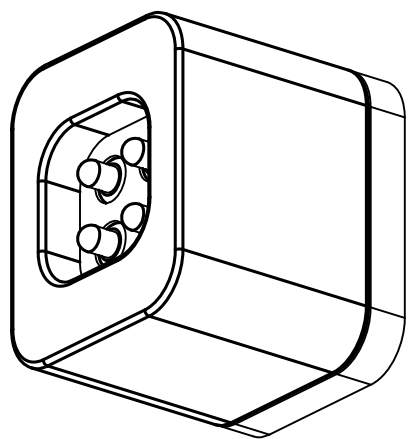

VER.	DESCRIPTION	EON NO.	DATE
------	-------------	---------	------

DRAWN	DATE	SCALE	VER.	VERSION	TITLE	PROJECT	DRAWING NO.	UNIT	SHEET	OF	PROJECT	DATE	SCALE	VER.	VERSION	PROJECT	DRAWING NO.	UNIT	SHEET	OF	PROJECT	DATE	SCALE	VER.	VERSION	
lys	2022.06.15	10:1	A.0		pogo pin connector.	NC4809-04PA	mm	1	1	1	1	1	1	1	1	1	1	1	1	1	1	1	1	1	1	1

东莞市燊瑞电子科技有限公司

Ang: ±1°
Dim: 0 ±0.20
.0 ±0.5*
.00 ±0.25*