

Please Approve this Drawing

Date

Signature

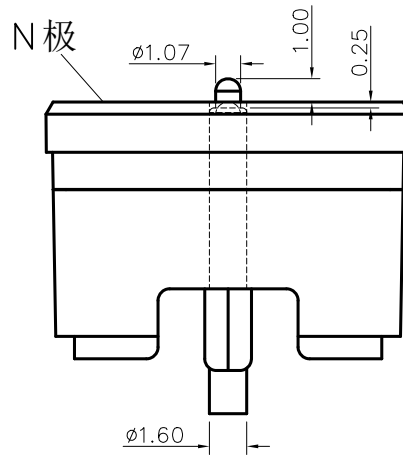
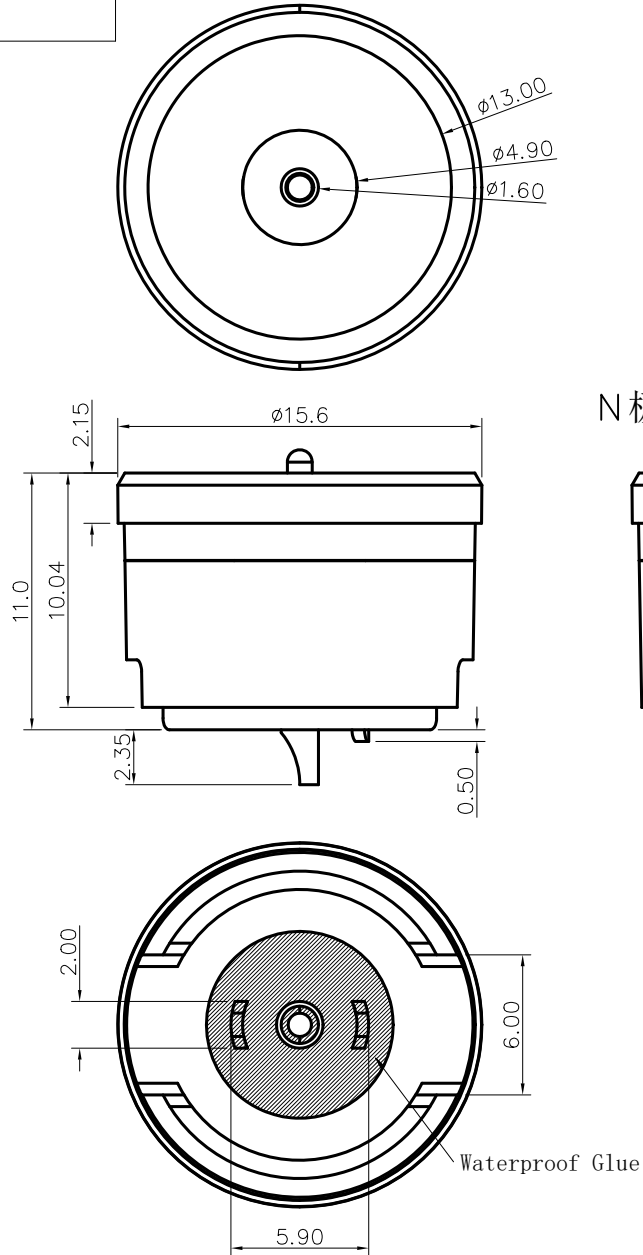

Pogopin  
.Salt Spray: 72 Hours

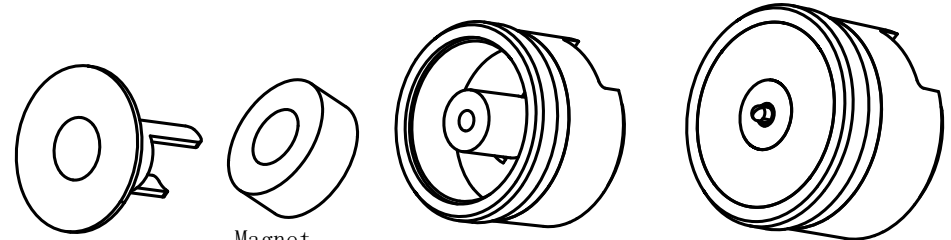

Shell  
.Salt Spray: 72 Hours



Magnet  
.Salt Spray: 48 Hours

Housing

NO.	Part Name	Q'TY	Material	Plated surface
1	Plunger	1	Brass	Au 20u" Min. Over 50u" Min. Ni
2	Barrel	1	Brass	Au 20u" Min. Over 50u" Min. Ni
3	Spring	1	SUS304	/
3	Magnet	1	NdFeB	200~400 U" NI
4	Shell	1	Brass	200~400 U" NI
5	Housing	1		HTN; UL94 V-0 Color Black

NOTES:

- Electrical  
.Rated Current & Voltage : DC 60 V ; 3.0A Max.  
.Contact Resistance: 30 mohm maximum  
at Working Height(Quiescence)
- Mechanical  
.Full store: 1.25 mm  
.Working Store: 1.00 mm  
.Spring Force: 100gf±20%gf at Working Height  
.Durability:100,000 cycles(minimum)
- Environmental  
.Operating Temperature: -25°C~+85°C  
.Humidity Range: 10%RH~90%RH  
.Salt Spray: 48 Hours  
.Dustproof and waterproof: IP54
- When the current is greater than 1A then need to increase the time delay circuit(3 second)
- To avoid arcing issue, The adaptor start to power supply after connector mated fully.
- To ensure the best usage,please operate it based on the working height.
- .RoHS&HF compliant product.

DRAWN	lys	DATE	2023.07.19			 <b>Dongguan Promax Electronics Technology Co., Ltd.</b>	
CHECKED		SCALE	10:1	VER.	A.0		
APPROVED		TITLE	pogo pin connector.			Ang:	
PROJECT		DRAWING NO.	NC6230-01PA			0 ±1°	0 ±0.20
SHEET	1 of 1	UNIT	mm			.0 ±0.5°	.0 ±0.15
						.00 ±0.25°	.00 ±0.10

VER.	DESCRIPTION	ECN NO.	DATE